

双龙集团有限公司

上海 | 总部
地址: 上海市嘉定区南翔工业开发区德力西路299号
电话: 400 622 6268

SHUANGLONG GROUP CO., LTD.

Shanghai (Headquarters)
Address: No. 299, Delixi Rd, Jiading District, Shanghai
Tel: 400 622 6268

Further products-更多产品, 详见官网www.shuanglong.com



* 因发展需要, 本公司保留设备规格、外形、配置变更的权利(资料如有不符, 以实物为准)。
* 本资料中图片和数据归我公司所有, 未经允许, 任何公司和个人不得使用, 否则, 追究其法律责任。



双龙集团官方微信



双龙集团官方网站

WLDH系列 卧式螺带混合机
Ribbon Mixer



卓越品质 EXCELLENT QUALITY

卧式螺带混合机由U形筒体、螺带搅拌叶片和传动部件组成; 螺带状叶片一般做成双层, 工作时外层螺带将物料从两侧向中央汇集, 内层螺带将物料从中央向两侧输送, 形成对流混合。搅拌部件还可以制作成桨叶式或增加飞刀, 适应不同的物料。筒盖可做成拱形或全开式, 拱形可以承压, 全开式方便清洗设备内部。本机的优点是适用范围广、混合均匀度高、混合时间短、装载系数大。

Ribbon mixer consists of U shape shell, double ribbons and drive unit. The outer ribbon transfer raw material from the two ends to centre while the inner ribbon moves the material in opposite in form of counter-current movement. Ribbons can be changed into paddles, and chopper is optional for different materials. The top cover can be concave for pressure application, or Fully-opened design for cleaning easily. The advantage of ribbon mixer are wide application, high mixing precision, short mixing time and large loading ratio.

可选项 | Options



搅拌器易调节和更换
Adjustable and replaceable agitator

混合筒体由碳钢或30408-31603不锈钢制成
Mild steel, Stainless Steel
30408~31603 optional for construction material

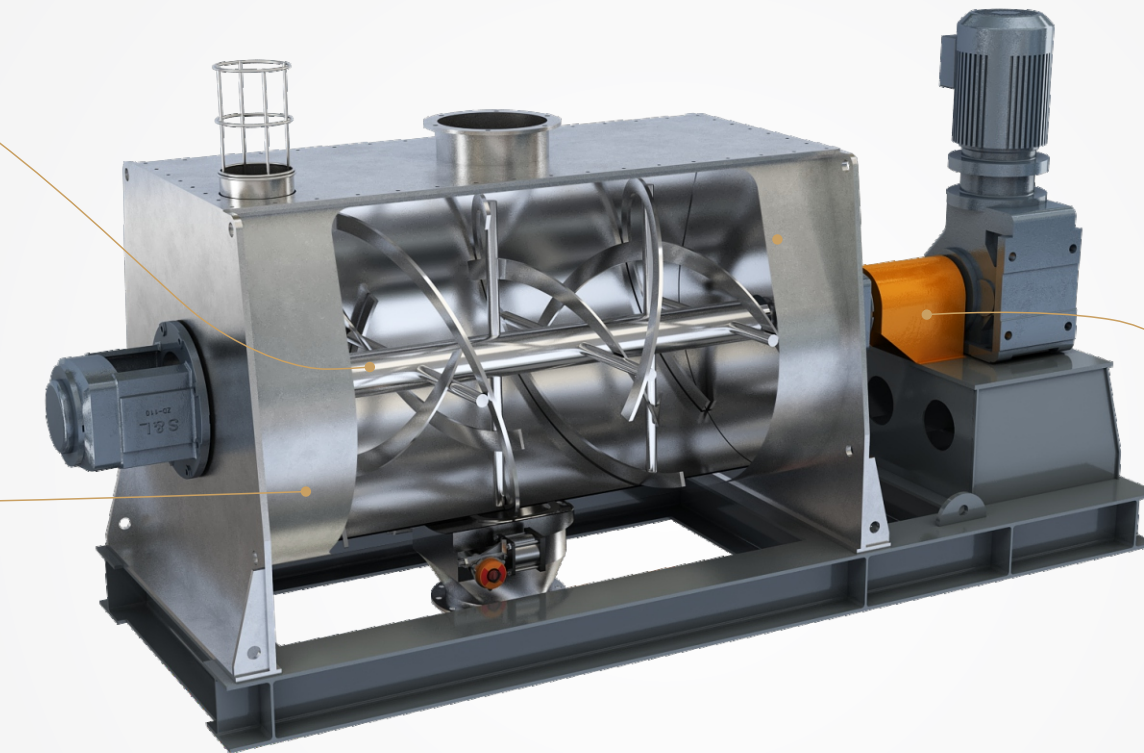

容易清洗和接触到搅拌机内部所有部件
Easy cleaning and access to any parts inside

轴密封采用平衡组合密封(专利)结构, 可选气密主件
Counter balance seal assembly for main shaft (with Patent Certificate)
Air purge seal is optional

- 最佳的混合均匀度
- 最短的混合时间
- 出色的重复性批次混合
- 极小磨损/低维修率
- 容易接触到混合机的各部位
- Excellent Mixing Effect
- Rapid Mixing Time
- Duplicable Production
- Wear-resistance / Low Maintenance Rate
- Easy Access To Any Parts

高新技术企业 | 高端混合机领导者
NEW HIGH-TECH ENTERPRISE
LEADING MANUFACTURER OF POWDER MIXING EQUIPMENT

精密制造

PRECISED FABRICATION



标准型
Standard Design



圆筒体卧式螺带混合机
Horizontal Ribbon Blender
with Round Vessel



大开门出料型
Bomb door for discharging



卫生级
Hygiene Level



全夹套型
Complete Jacket



蜂窝夹套型
Dimple Jacket



飞刀型
Chopper Design



U型筒体
U Shape Vessel

标准配置 | Standard Configuration



硬齿面齿轮减速机
Hardened Gear
Reducer



气控箱
Air Control Box



标准搅拌器
Standard Agitator

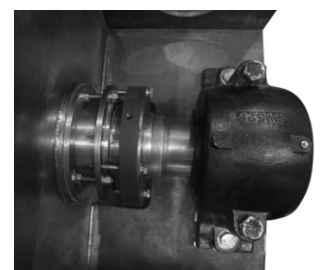

四氟恒压机械
密封装置
Constant Pressure
With Ptfе
Mechanical Seal



设备可选配雾化喷头或喷淋头,使雾化的液体成扇形、空圆锥形均匀的喷向物料,以达到均匀充分混合,满足不同工艺的需求。

Atomizing nozzles or spraying nozzles are available on request. creating fan shape or hollow cone, Liquid flow into mixtures to reach intensive mixing.



应用范围 | Applications



食品 Food



医药 Pharmaceutical Product



生物制品 Bioproduct



化工 Chemicals



电池 Battery



建材 Building Materials



染料 Dyestuff



颜料 Pigment



EPS发泡塑料
EPS expanded plastic



农药 Pesticide

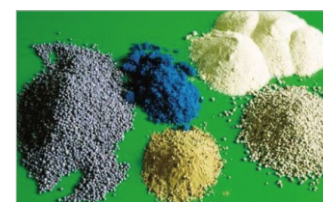

肥料 Fertilizer



高分子材料 Polymer Material

创新技术

INNOVATED TECHNOLOGY

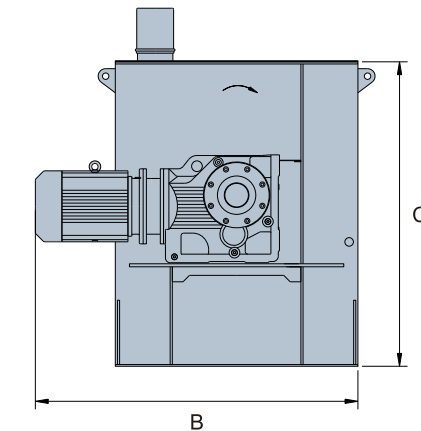
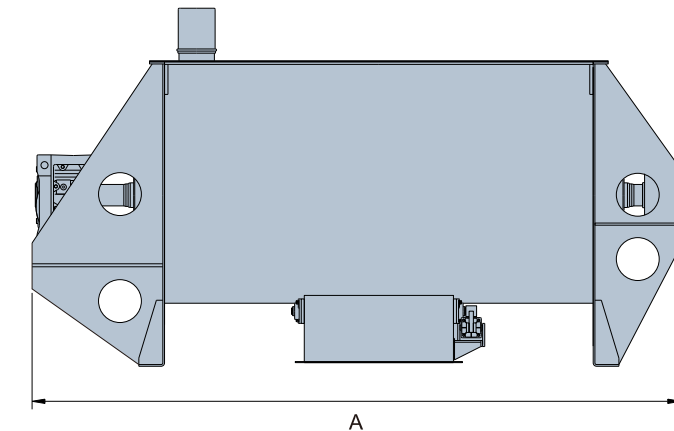

Model 型号	A	B	C	Working Volume 可用容量 (dm ³)	Dry Weight 空载重量 (kg)
WLDH-0.1	1190	740	770	0.7	330
WLDH-0.3	2030	630	980	0.21	720
WLDH-0.5	2320	730	1130	0.35	980
WLDH-1	2800	920	1320	0.7	1700
WLDH-1.5	2180	1020	1550	1.05	1800
WLDH-2	3310	1120	1640	1.4	2100
WLDH-3	3750	1290	1820	2.1	3000
WLDH-4	4220	1400	1990	2.8	3980
WLDH-5	4220	1500	2100	3.5	4620
WLDH-6	1700	1610	2260	4.2	6180
WLDH-8	4420	2150	2470	5.6	8200
WLDH-10	5520	2960	2720	7	8920
WLDH-12	5720	3010	2840	8.4	9520
WLDH-15	5840	3540	2940	10.5	9950
WLDH-20	6300	2374	2930	14	10970
WLDH-25	6660	2554	3110	17.5	11890

1. 设备的装载量因物料特性和使用工艺不同而有所变化;
2. 物料比重大、有粘性、长时间沉积不可负载启动。



经中国合格评定国家认可委员会 (CNAS) 认证注册的实验室,发布于2009年3月28日
Released by lab registered to China National Accreditation Service for Conformity Assessment (CNAS) on March 28, 2009

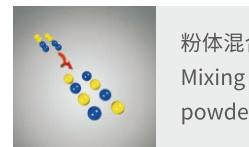

粉体混合
Mixing of
powders

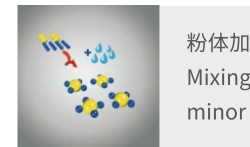

粉体加少量液体混合
Mixing of powders and
minor amount liquids

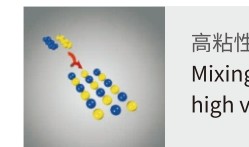

高粘性物料的混合
Mixing of material with
high viscosity

美好未来

BRIGHT FUTURE

发展历程 | BRIGHT FUTURE

- 1989 满怀创新理念, 创立上海双龙混合机厂。
- 1991 引进美国技术, 开发出卧式螺带混合机。
- 1992 与韩国SIJI公司合作, 首家在中国生产无重力双轴桨叶混合机, 开创高精度粉体混合的先河。
- 1993 引进德国技术, 开发出犁刀式混合机。
- 1994 为欧美、韩国提供OEM产品。
- 1995 更名为上海双龙混合设备制造有限公司。
- 1996 开发出三螺旋锥形混合机, 专门用于明胶、钛白粉等行业。
- 2001 成立上海双龙防爆电机有限公司, 建立自主电机生产基地。
- 2007 更名为: 双龙集团有限公司。
- 2014 上海总部实现装备技术升级, 大型全自动智能装备投入生产, 全力打造高精、高端产品。
- 2018 进军锂电原料加工行业, 浙江生产基地投产。
- 2022 目前, 双龙集团在中国拥有3家子公司、3个生产基地。其用户遍及全球60多个国家, 极大的扩大了公司的知名度。凭借激情上进的员工队伍, 以及技术创新、品质卓越的产品, 双龙公司已整装待发、面向未来, 迎接挑战!